



LPES Small Farms Fact Sheets*



Photos courtesy of USDA NRCS.

The ABCs of Electric Livestock Fencing

By Ben Bartlett, Michigan State University

Summary

A good fence should keep your livestock in; last 25 to 30 years without major rebuilding, repair, or replacement; and be low cost and easy to build. The cost of most fences is half labor and half materials. For a truly low-cost fence, use only high-quality, long-life materials. The most critical element of an electric fence is maintaining an adequate voltage charge.

MWPS



EPA

*Now available online at www.lpes.org.



Fencing Principles

This fact sheet reviews the principles and practices that will help you to build an effective electric livestock fence. Electric fence is often lower in cost and easier to build than physical barrier fences. Physical barrier fences—barb wire, page wire, or board fences—should be used when (1) the electric fence may be dangerous to children or (2) animals can be crowded into fence by other animals or people. The key to building a good electric fence is to follow the principles outlined in this fact sheet. It does not cover temporary or movable fencing. There are many temporary options, but the key is to have an effective perimeter fence that keeps your animals on your farm or ranch.

Design and Layout

The first step in fence building is deciding where you want the fence and what kinds of livestock you want to fence in or out. Using an aerial photo from your Farm Service Agency office, plan your fencing project so that your permanent perimeter fences

and gates will be in the right place for years to come.

The next step is to draw a diagram of your fence system as it will look when completed. You do not have to be a draftsman or draw the fence to exact scale. But a diagram will help you order materials and build the fence. This drawing also helps for future fence projects.

A pencil diagram can be easily changed to compare layout options.

A pencil diagram is easily changed with an eraser. It allows different fence designs to be compared that will minimize materials while getting the gates in the best locations.

Fence design is determined by the species of animal being fenced, the livestock or wildlife population or pressure, and the “cost” of an escape (Figure 1a, b, and c). (That is, are you fencing your cows out of the woods or out of the neighbor’s prize rose garden?)

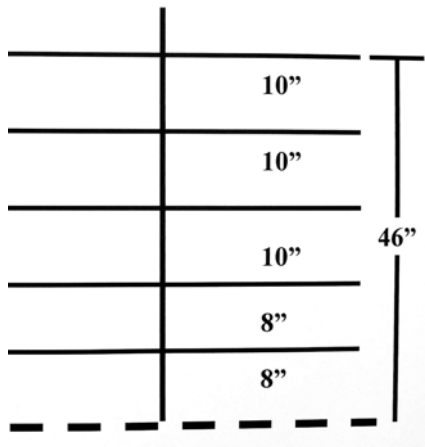

a. Five-wire cattle fence.

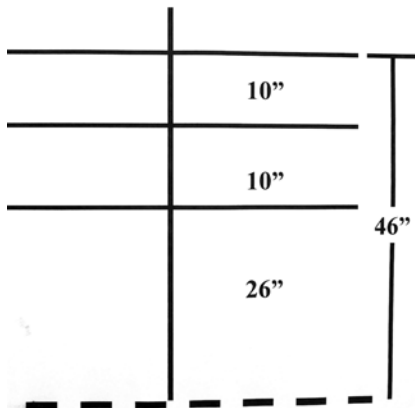

b. Three-wire horse fence.

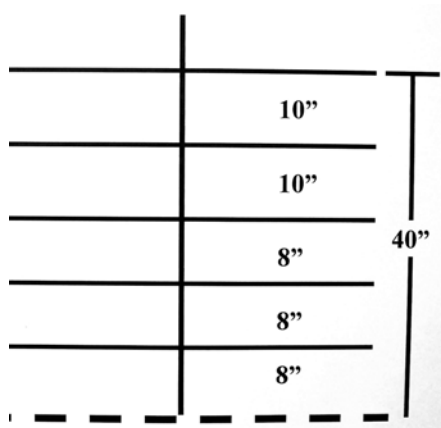

c. Five-wire sheep/goat fence.

Figures 1a, b, and c. Fence wire designs.

Never use less than three wires for a perimeter fence. If you are not sure about how many wires to use, choose the design with one more wire. It is a lot easier to build a fence with one more wire than to try to add an extra wire later.

Materials and Tools

Let's talk about the fence chargers, or energizers (Figure 2). The right charger combined with quality construction is what makes electric fence effective. An electric fence is a psychological barrier to animals the same way a sign that says "Danger—Dynamite" is a psychological barrier to humans. A "Danger—Dynamite" sign is only effective for people for people if they can read, and an electric fence is only effective for animals if they have been taught the wire will "bite." To obtain adequate bite, or voltage, takes the right size of fence charger that is properly grounded. Because so many different kinds and sizes of chargers are available, ask a reputable fence dealer for advice when you select a charger.

Good grounding is critical, and you will need about three feet of ground rod per joule. (Joule is like a horsepower rating for chargers. Your dealer can supply this



Figure 2. Fence charger.

information.) To achieve adequate grounding, you may have to go really deep with your ground rods or use many ground rods. Poor grounding is one of the most common causes of low fence voltage.

Good grounding is critical.

All 12½-gauge, high-tensile wire is similar, but breaking

strength varies from 1,300 to 1,800 pounds. The 1,800-pound wire is somewhat stronger but is slightly more expensive and stiffer to work with. To give a useful life of 25 to 40 years, make sure the wire is triple galvanized or zinc coated to prevent rust.

The end or corner posts should be large, 5 to 7 inches in diameter, treated wood posts at least 8 feet long. The strength of larger posts is needed to prevent breaking (Figure 3), and the larger size resists leaning due to ground resistance. Since corner posts are the foundation of the fence system, only treated posts that will last 25 to 40 years should be used. There are other corner options, such as steel and concrete, and single, very deeply planted poles. Any option should be unmovable and last 25 to 40 years.

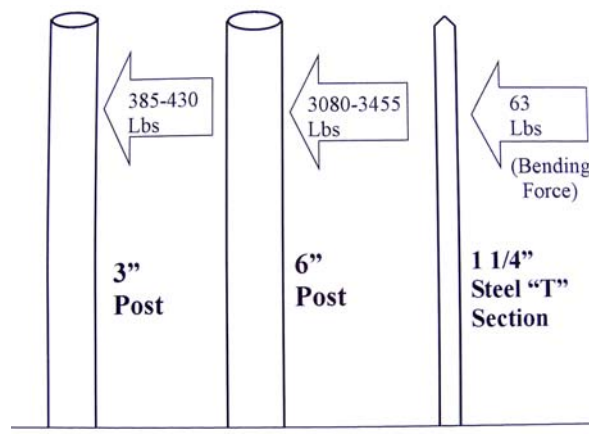

Figure 3. Fence post strength (breaking force required for wood post).



Line posts can be wood, fiberglass, or steel. All have different cost, installation, and use pros and cons. Since line posts function only to maintain wire spacing and can be replaced, personal preference, cost, or ease of installation usually determines the final choice.

As the saying goes, little things can make a big difference. If we use corner posts and wire lasting 25 to 40 years, the corner insulators should be of equal quality. Use only porcelain, high-quality polyethylene, or quality wrap-around end insulators that have a warranty (Figure 4). Line post insulators are replaceable, but it is cost effective to buy the best the first time because of the labor required.



Figure 4. Plastic and ceramic insulators.

Wire strainers are ratchets that can be turned to adjust the

tension on the fence wire (Figure 5). There are many different kinds of wire strainers with various pros, cons, and costs. Most importantly, use a strainer that is stronger than the wire.



Figure 5. Strainer and handle.

Other items you may need for your fence project include cut-off switches, underground insulated cable, strainer handles, ground rods with clamps, and tension springs. Tension springs have only proven useful for short stretches of fence (200 ft or less). Longer stretches have more wire elasticity than what the tension springs allow.

Tools that will be needed include a digger or post driver for the corner posts and a wire payout spinner. The wire can be fastened together with either special knots or a crimp sleeve. The figure of eight knot or reef knot (Figure 6) reduce wire



strength by 30% but do not require special tools.

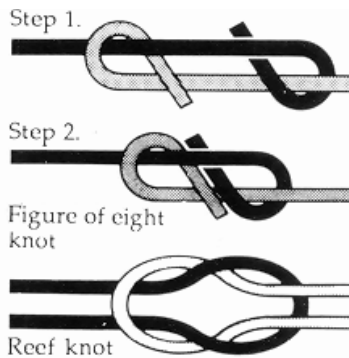

Figure 6. Wire knots.

The crimping tool used with crimp sleeves maintains wire strength and is quicker, but it has the added expense of tool and sleeves. The crimp sleeve, which is figure eight in shape (Figure 7), should not be confused with the tube type or round sleeve, which has not worked well with high-tensile wire.



Figure 7. Wire crimp sleeves.

Other tools such as pliers, chain wire tighteners, hammers, and shovels are also needed but

are not unique to fence construction.

Make sure your perimeter fences are on your side of the legal boundary.

Construction Principles and Techniques

You may think you are ready to start planting posts, but two important items remain. First, make sure your perimeter fences are on the legal boundary between you and your neighbor. They also need to meet your state and county ordinances, including any signage required for electric fences. A little checking now can prevent lots of future problems with the new neighbors who want their one foot of property back. Second, since electric fence is a psychological barrier, wire spacing and visibility are critical. If your fence goes through a wooded area or rough terrain, site preparation is a must (Figure 8). Get a bulldozer in to level and clear a 10- to 16-foot area. This will improve fence visibility, make the fence easier to build and maintain,



and probably reduce the number of posts needed.

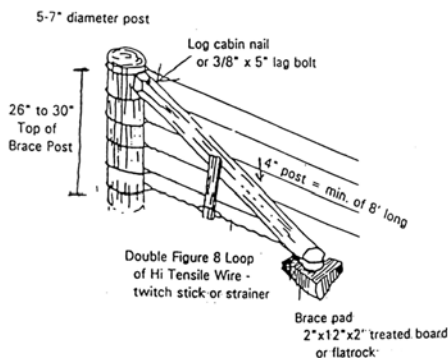

Figure 8. Site preparation.

If your fence goes through a wooded area or rough terrain, prepare the site.

Construction

Now we can start building. The corner or end post goes in first. In addition to using a large post, the depth is critical. Four feet is considered minimum depth.



a. Figure 4 end post. Figures 9a and b. End post assemblies.

If soil conditions are less than ideal or the depth is less than four feet, consider placing a bag of Redi Mix in the bottom of the hole after the post is in to prevent uplifting. Other options to prevent uplifting are a 2x4 cleat on the bottom of the post and rocks tamped against the bottom of the post.

To prevent post lean, a bed-log or board can also be put at ground level on the fence side of the post. The type and amount of bracing will depend on the number of wires in your fence. One- or two-wire cross fences will work with just a well-set single post. Three to six wires should have a figure 4 assembly (Figure 9a) or H brace assembly (Figure 9b). Over six wires need a single or double H depending on wires, soil conditions, and fence height.

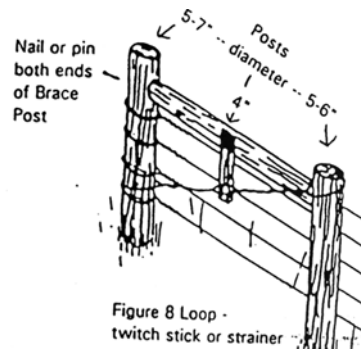

b. H brace end post.



After the end posts are set, string one wire to serve as a guide for the placement of the line post. A stretch of wire served by one strainer can be up to 4,000 foot on a level fence. Reduce the length by 1,000 feet for each 90 degree corner and 500 feet for every major rise or dip. Place strainers on fences over 600 feet long in the middle of the fence. Put wires that go around a corner on the back side of the post. The wire will slide around the large circumference of a post more easily than it will through the sharp corner of an insulator.

Do not over tighten fence wires.

For fence line posts, the distance between posts is determined by number of wires and levelness of the terrain. For cattle and horse fences on level ground where the wire is spaced 8 to 10 inches apart, posts can be up to 50 feet apart. With closer wire spacings, posts should be every 20 to 35 feet. Uneven fence lines require a post in every dip and on every rise. Hopefully your site prepa-

ration work has reduced the ups and downs in your fence line.

String the wire next. It can be completed by setting the payout spinner (Figure 10) at the corner post. Then pull the wire or attach the end of the wire and carry the spinner in a truck or trailer. After the wires are strung, go back and put in the strainers. Next put a small amount of tension on the fence. After all the wires are attached to the posts, you can apply the final tension. Wires should be tightened to 200 to 250 pounds of tension. Two hundred pounds just takes the sag out between posts. Cold weather will shrink wire and put additional stress on corner posts. Do not over tighten fence wires.

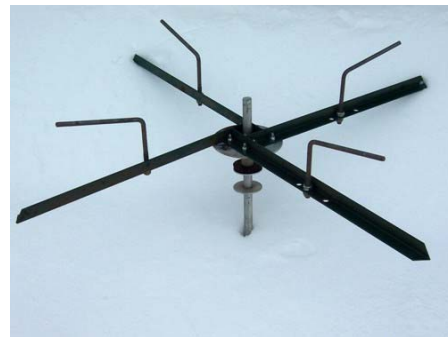

Figure 10. Pay out spinner.

The fence is almost done. Its ability to carry a good electrical charge depends on good connections. Take time to hook up



the charger, fence, and ground rods with good connections. To reduce the possibility of lightning damage, use an induction coil, 8 to 10 coils of 12-inch (in diameter) wire, and a lightning arrestor on wire that runs from the charger to the fence (Figure 11). See your fence dealer for installation.

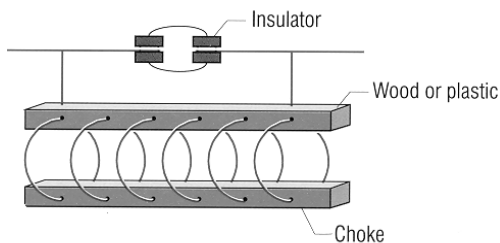

Figure 11. Induction coil/lighting choke.

The gate ways need to be finished. Gate way finishing includes installation of the underground insulated wire. To offer additional protection, the under gate wire should run through ½-inch black plastic pipes. Do not use Romex-type electrical wire. It is only labeled for 600 volts and will “leak” after being used for only a short

time. The actual gate can be a pipe or board swinging gate, wire or poly tape with handles, or a woven wire with a wire loop connector.

Conclusion

If you are headed for the barn door to let the livestock out, stop! You built a high-quality fence, but you still need to make sure the charge is effective. Test the fence with a fence volt meter (Figure 12).



Figure 12. Digital fence volt meter.

You want to make sure you have sufficient voltage to teach livestock that the fence is a barrier that “bites.” Then you can sit back and enjoy a job well done.



Points to Remember

- Your permanent fence is a long-term investment. The *planning* for where and how to build the fence before you start construction is *critical*.
 - It is easier and costs less over time to build fence with high-quality materials and proper construction principles.
-
- Fencing is a tool to control grazing animals. Maintain the fence, have a good grounding system, and test the voltage so the fence remains effective.



Author

Ben Bartlett, Dairy and Livestock Agent, Michigan State University, can be reached at 906-439-5880 or bartle18@msu.edu.

For More Information

Educational Resources

<http://www.lpes.org/>—To view the Livestock and Poultry Environmental Stewardship (LPES) curriculum resources

<http://www.reeusda.gov/1700/statepartners/usa.htm/>—To obtain state Cooperative Extension contacts

Environmental Regulations Resources

<http://www.epa.gov/npdes/afo/statecontacts/>—To obtain state environmental agency contact

Small Farm Resources

1-800-583-3071—USDA-CSREES Small Farm hotline

Building Fences, American Association for Vocational Instructional Materials

Turner, J. Howard, *Planning Fences*, American Association for Vocational Instructional Materials

1-800-292-0969 or muextension.missouri.edu—To purchase the *1996 Missouri Grazing Manual* from the University of Missouri Extension Publications

<http://www.attra.org>—National Sustainable Agricultural Information Service

Local NRCS Office and Cooperative Extension Office

Local fence dealers

Acknowledgments

The author wishes to thank Carol Galloway, EPA National Agriculture Assistance Center; Gary Wright, The Wright Place Fence and Fence Building; Dr. Randy James, The Ohio State University; Joe Maddox, Manager, West Ranch, Ozona, Texas; Donald Nevill, Nevill Supply, Fence, and Water Systems; Betsy Dierberger, USDA NRCS Michigan Grazing Specialist; and Rob Rutherford, University of California, Cal-Poly for their review of this fact sheet.

The author also wishes to thank Diane Huntrods, the LPES Project Manager, for editing this fact sheet and coordinating its completion.



Financial Support

The LPES Small Farms Fact Sheets were developed with support from the USDA-CSREES, U.S. EPA's National Agriculture Assistance Center, and University of Nebraska Cooperative Extension at Lincoln, under Cooperative Agreement Number 2003-39490-14107.

*Copyright © 2006 by MidWest Plan Service.
Iowa State University, Ames, Iowa 50011-3080.*

Copyright

For copyright permission, contact MidWest Plan Service (MWPS) at 515-294-4337. Organizations may reproduce this fact sheet for non-commercial use, provided they acknowledge MWPS as the copyright owner and include the following credit statement:

Reprinted from the LPES Small Farms Fact Sheets, authored by Ben Bartlett, Michigan State University, courtesy of MWPS, Iowa State University, Ames, Iowa 50011-3080
Copyright © 2006.